

PRODUCT NUMBER	DESCRIPTION
88917-101 & -101LF	HEAT STAKE VERSION

FRONT VIEW

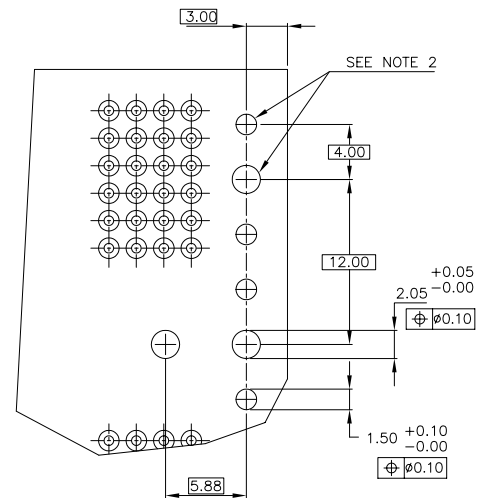
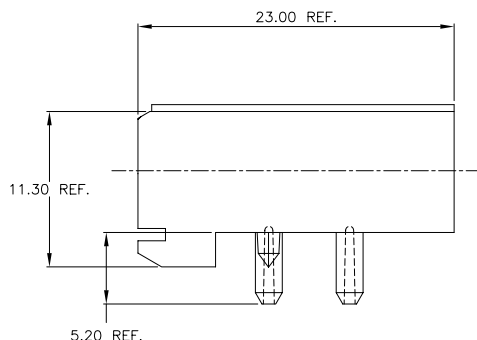
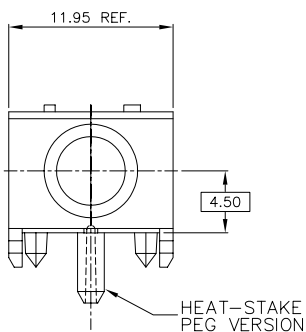

REQUIRED PC BOARD LAYOUT
COMPONENT SIDE

NOTE:

- HOUSING MATERIAL: LCP, 30% GLASS FILLED
FLAME RETARDANT PER UL 94V-0.
COLOR: NATURAL
- INDICATED HOLES ARE UNPLATED
- PART NUMBER WITH "LF" SUFFIX AT THE END ARE LEAD FREE OPTION
- THIS PRODUCT MEETS EUROPEAN UNION DIRECTIVES AND OTHER
COUNTRY REGULATION AS DESCRIBED IN GS-22-008.
- THE HOUSING WILL WITHSTAND EXPOSURE TO 260°C PEAK
TEMPERATURE FOR 15 SECONDS IN A WAVE SOLDER APPLICATION
WITH A 1.5mm MINIMUM THICK CIRCUIT BOARD OR FOR 10-20
SECONDS IN A CONVECTION, INFRA-RED OR VAPOR PHASE REFLOW
OVEN. SEE APPLICATION NOTES/PROCEDURES IF THEY ARE AVAILABLE.

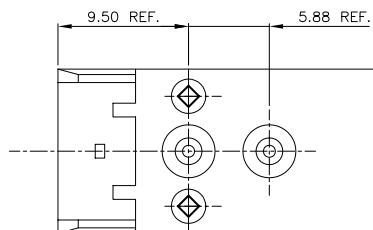
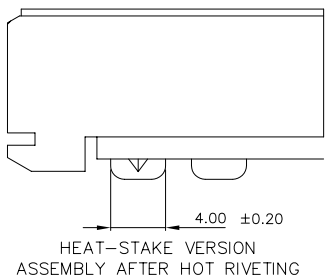

mat'l. code		surface		tolerance		projection		product family	
SEE NOTES		ISO 1302 ✓		ISO 406 ISO 1101		mm		METRAL ACC.	
ltr	ecn	no	dr	date	tolerances unless otherwise specified		title		
F	c80040	MDF		7/23/98	angles	linear	RECEPTACLE GUIDE MODULE, 4 ROW		
G	H80473	MDF		7/23/98			scale 1:1		
H	v02701	JWS		10/19/00	σ±2'		mm		
J	v11668	LSS		6/13/01	dr	S. STONER	9/30/93		
K	v12868	CGD		1/02/02	enrg	R. DOUTRICH	9/30/93		
L	M05-0262	MHT		12/20/05	chr	S. STONER	9/30/93		
M	M06-0286	MNR		7/27/06	appd	S. STONER	9/30/93		
sheet	revision	M	M	M	M	M	FCI		
index	sheet	1	2	3	4		88917		
								sheet 1 of 4 size A3	
								type Product Customer Drawing	



Copyright FCI

PRODUCT NUMBER	DESCRIPTION
88917-201 & -201LF	PRESS-PEG VERSION

FRONT VIEW

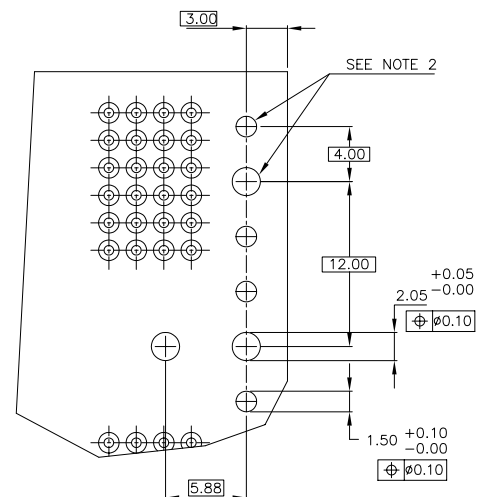
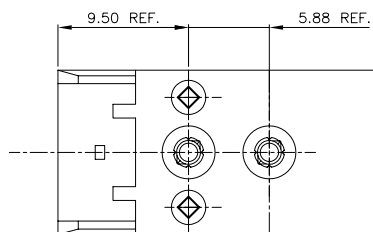
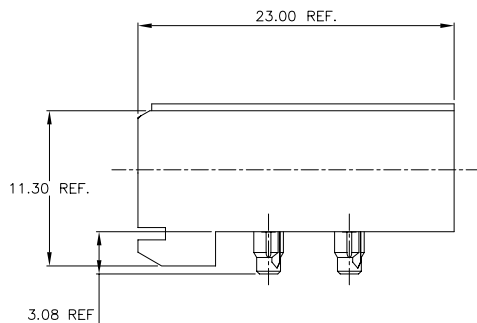
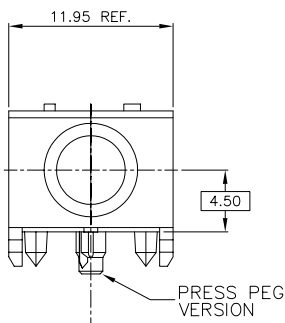

REQUIRED PC BOARD LAYOUT
COMPONENT SIDE

NOTE:

- HOUSING MATERIAL: LCP, 30% GLASS FILLED
FLAME RETARDANT PER UL 94V-0.
COLOR: NATURAL
- INDICATED HOLES ARE UNPLATED
- PART NUMBER WITH "LF" SUFFIX AT THE END ARE LEAD FREE OPTION
- THIS PRODUCT MEETS EUROPEAN UNION DIRECTIVES AND OTHER
COUNTRY REGULATION AS DESCRIBED IN GS-22-008.
- THE HOUSING WILL WITHSTAND EXPOSURE TO 260°C PEAK
TEMPERATURE FOR 15 SECONDS IN A WAVE SOLDER APPLICATION
WITH A 1.5mm MINIMUM THICK CIRCUIT BOARD OR FOR 10-20
SECONDS IN A CONVECTION, INFRA-RED OR VAPOR PHASE REFLOW
OVEN. SEE APPLICATION NOTES/PROCEDURES IF THEY ARE AVAILABLE.

mat'l. code		surface		tolerance		projection		product family	
SEE NOTES		ISO 1302 ✓		ISO 406 ISO 1101				METRAL ACC.	
ltr	ecn	no	dr	date	tolerances unless otherwise specified				
M					angles	linear	xx ±.01/.3	title	
					0°±2'		xxx ±.005/.13	RECEPTACLE GUIDE	
							xxxx ±.0020/.050	MODULE, 4 ROW	
					dr	S. STONER	9/30/93	scale 1:1	
					enrg	R. DOUTRICH	9/30/93	dwg no	
					chr	S. STONER	9/30/93	88917	
					appd	S. STONER	9/30/93	sheet 2 of 4	
sheet		revision		size					
index		sheet		A3					
				type Product Customer Drawing					

FCI
FCIconnect.com

Copyright FCI

PRODUCT #	DESCRIPTION
88917-301 & -301LF	SCREW DOWN VERSION

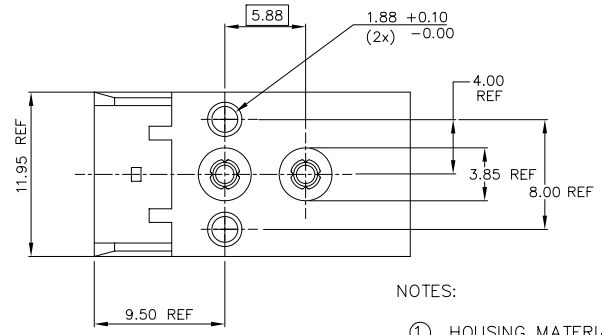
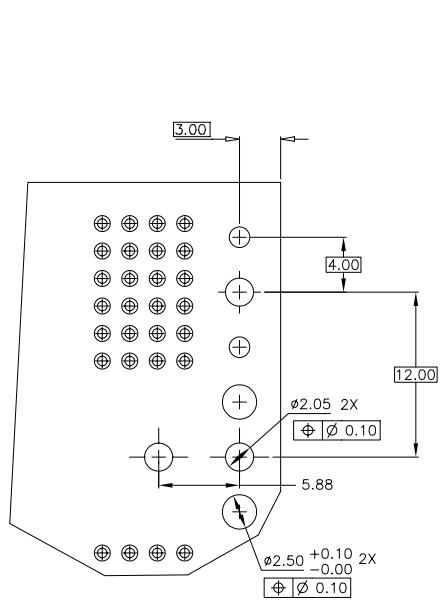
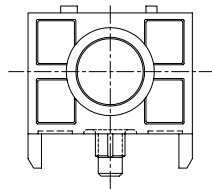
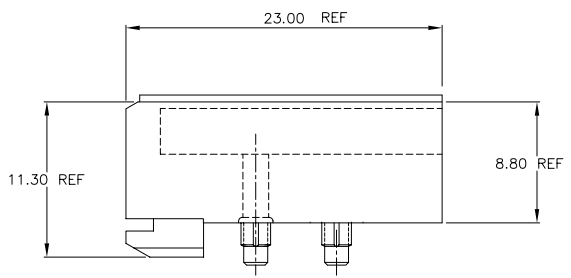
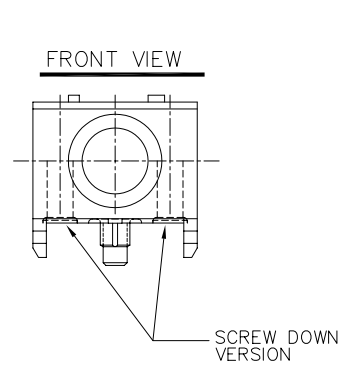

NOTES:

- HOUSING MATERIAL: LCP, 30% GLASS FILLED FLAME RETARDANT PER UL 94V-0. COLOR: NATURAL
- TWO MOUNTING SCREWS, P/N 63787-001, FOR MAX PCB THICKNESS 2.4mm [0.094"] OR P/N 63787-002 FOR MAX PCB THICKNESS 3.2mm [0.126"]. MUST BE ORDERED SEPARATELY
- THE MATING CONNECTOR FOR THIS APPLICATION MUST USE A WALL-LESS HEADER HOUSING, P/N 63735-101, TO AVOID INTERFERENCE WITH MOUNTING SCREW HEADS.

REQUIRED PC BOARD LAYOUT COMPONENT SIDE

- PART NUMBER WITH "LF" SUFFIX AT THE END ARE LEAD FREE OPTION
- THIS PRODUCT MEETS EUROPEAN UNION DIRECTIVES AND OTHER COUNTRY REGULATION AS DESCRIBED IN GS-22-008.
- THE HOUSING WILL WITHSTAND EXPOSURE TO 260°C PEAK TEMPERATURE FOR 15 SECONDS IN A WAVE SOLDER APPLICATION WITH A 1.5mm MINIMUM THICK CIRCUIT BOARD OR FOR 10-20 SECONDS IN A CONVECTION, INFRA-RED OR VAPOR PHASE REFLOW OVEN. SEE APPLICATION NOTES/PROCEDURES IF THEY ARE AVAILABLE.

mat'l. code		surface		tolerance		projection		product family	
SEE NOTES		ISO 1302 ✓		ISO 406 ISO 1101				METRAL ACC.	
ltr	ecn	no	dr	date	tolerances unless otherwise specified				
M					angles	linear	xx ±.01/.3 xxx ±.005/.13		title
					0°±2'		mm		RECEPTACLE GUIDE MODULE, 4 ROW
					dr	S. STONER	9/30/93	scale 1:1	
					enfr	R. DOUTRICH	9/30/93	dwg no	
					chr	S. STONER	9/30/93	sheet 3 of 4 size	
					appd	S. STONER	9/30/93	A3	
sheet		revision		type Product Customer Drawing					
index		sheet							

FCI
FCIconnect.com
Copyright FCI

1	2	3	4	5	6
PRODUCT #	DESCRIPTION				
88917-401 & -401LF	CLAW RETENTION VERSION				

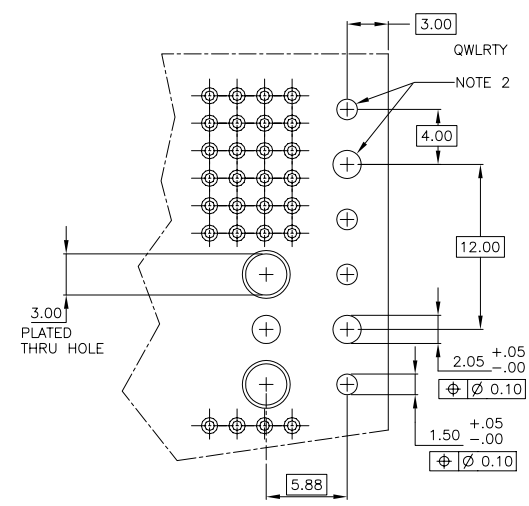
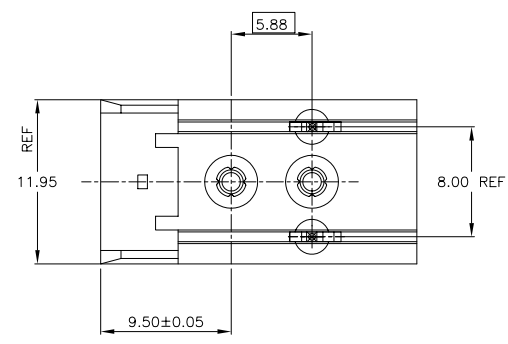
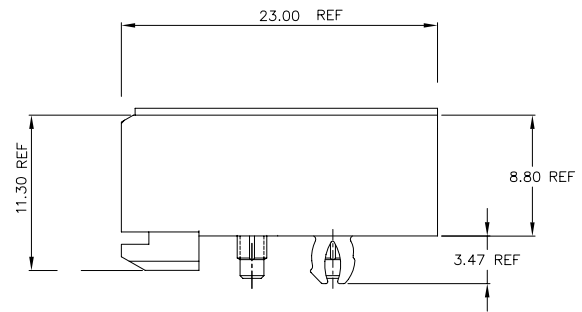
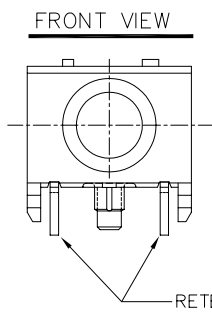

REQUIRED P.C. BOARD LAYOUT COMPONENT SIDE

NOTES:

- ① HOUSING MATERIAL: LCP, 30% GLASS FILLED FLAME RETARDANT PER UL 94V-0. COLOR: NATURAL
- ② INDICATED HOLES ARE UNPLATED.

- ③ PART NUMBER WITH "LF" SUFFIX AT THE END ARE LEAD FREE OPTION
- 4. THIS PRODUCT MEETS EUROPEAN UNION DIRECTIVES AND OTHER COUNTRY REGULATION AS DESCRIBED IN GS-22-008.
- 5. THE HOUSING WILL WITHSTAND EXPOSURE TO 260°C PEAK TEMPERATURE FOR 15 SECONDS IN A WAVE SOLDER APPLICATION WITH A 1.5mm MINIMUM THICK CIRCUIT BOARD OR FOR 10-20 SECONDS IN A CONVECTION, INFRA-RED OR VAPOR PHASE REFLOW OVEN. SEE APPLICATION NOTES/PROCEDURES IF THEY ARE AVAILABLE.

mat'l. code		surface		tolerance		projection		product family	
SEE NOTES		ISO 1302 ✓		ISO 406 ISO 1101				METRAL ACC.	
ltr	ecn	no	dr	date	tolerances unless otherwise specified		title		
M					angles	linear			
					°±2'	xxx ±.01/.3	RECEPTACLE GUIDE		
						xxx ±.005/.13	MODULE, 4 ROW		
						xxxx ±.0020/.050	scale 1:1		
			dr	S. STONER	9/30/93			dwg no	
			enfr	R. DOUTRICH	9/30/93			sheet 4 of 4	
			chr	S. STONER	9/30/93			size	
			appd	S. STONER	9/30/93			A3	
sheet	revision								type
index	sheet								Product Customer Drawing

FCJ
 FCconnect.com
 Copyright FCJ